

## Quilting

A quilt is defined as two layers of fabric with a filler layer in between. The layers are sewn together either by hand or machine. Quilt tops may be whole cloth or patchwork, appliqued or pieced. Once the top has been completed, it is ready to assemble into a quilt.

### TRANSFERRING THE QUILT DESIGN

There are many methods as well as marking tools available for use on quilts. Choose markers that will produce a thin, light line. When selecting, make test marks on scrap fabric to check for visibility and ease of removal if necessary.

*Marking lines should never be visible on your finished project.* A No. 2 lead pencil works well on light-colored fabric. Keep pencil sharpened throughout the marking process. White or yellow chalk marking pencils are recommended for dark colored fabrics.

- **Tracing**

This method works best with light-colored fabric and allows all designs on the quilt top to be marked *prior* to basting the quilt together.

Select a quilting design. If necessary, darkly trace onto paper so that designs show through when fabric is positioned over it. A light source placed under the design can help to make it more visible. A light box or sunny window works well. To create a light box, place a lamp (shade removed) under a glass top table. Tape the paper pattern to the glass top. Place the fabric area to be marked over the pattern and trace with a pencil. Reposition fabric as needed to complete design transfer. *Mark fabric with a thin, light line. Markings should not be visible on finished project.*

- **Stencil or Template**

There are other transfer methods available that allow the quilt to be marked *AFTER* it is basted.

Stencils or templates can be used for this purpose and work well on darker fabrics. Also, marking designs just before quilting keeps lines from fading out or rubbing off.

Plastic stencils can be purchased with precut slits forming design. Simply position stencil over fabric area to be quilted and mark through the slit openings to transfer pattern. Mark dark fabric with white or yellow pencil; light fabric with No. 2 pencil, pumice powder or chalk.

Sheets of blank template plastic or lightweight cardboard can be used for creating original designs. Transfer designs onto template and use scissors to cut out shape. Position this template on quilt surface and lightly trace on fabric, then quilt area.

Precut paper patterns can also be purchased. These can be used repeatedly 20 to 40 times.

- **Freezer Paper**

Freezer paper makes an excellent, inexpensive template. Place freezer paper, dull side up, over design and trace. Cut out freezer paper shape and place waxy side of template against fabric. Apply hot, dry iron two to three seconds over paper. The waxy side of the paper temporarily adheres to the fabric. Trace around paper. After marking shape, peel off fabric and reposition for multiple markings.

- **Masking Tape**

Masking tape can be used on fabric for straight-line quilting. Position the tape on the fabric and hand- or machine-quilt next to the tape's edge. Tape can be removed and repositioned over and over.

There are lots of quilting designs to be found in quilting books and quilting stores. Below are some examples of designs that may be used for both hand and machine quilting. Another option is to “quilt in the ditch.” This method requires no additional markings as the stitching is done in the seam lines of the pieced top.

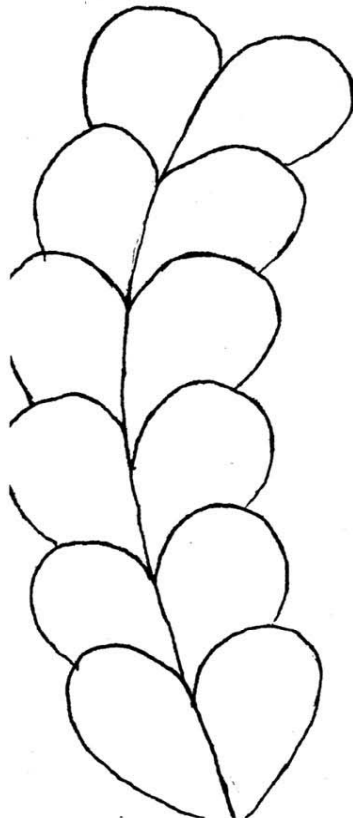

Quilting Design

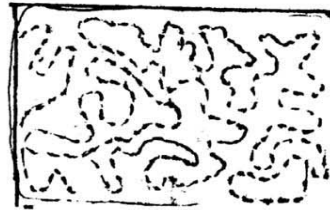

Stipple Quilting

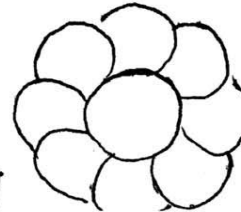

Quilting Design

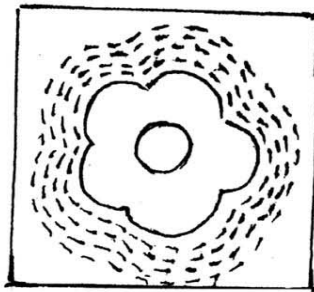

Echo Quilting

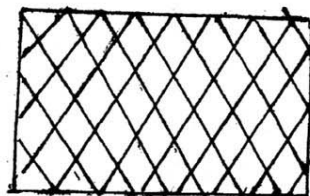

Diamonds

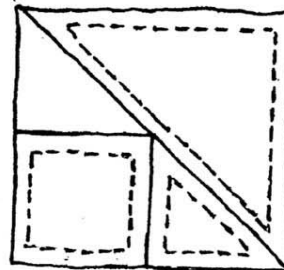

Outline Quilting

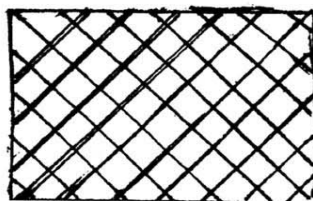

Cross Hatching

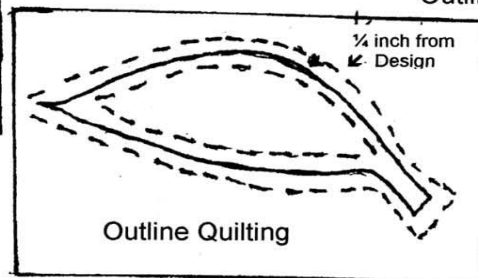

Outline Quilting

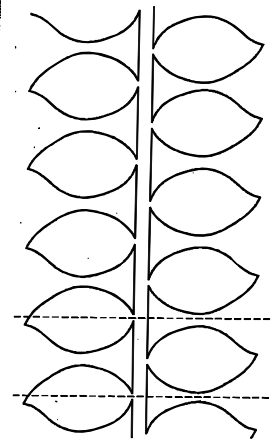

Continuous Line Quilting

Continuous line patterns are designed specifically for machine quilting and to allow the quilter to stitch continuously without having to stop the machine and start again. These are the easiest to do with free motion machine quilting (free form).

## BASTING

Basting temporarily secures three layers together so they can be handled while quilting. It is often done with long hand stitches but sometimes with safety pins.

A quilt is made up of three layers forming a quilt sandwich as shown below:

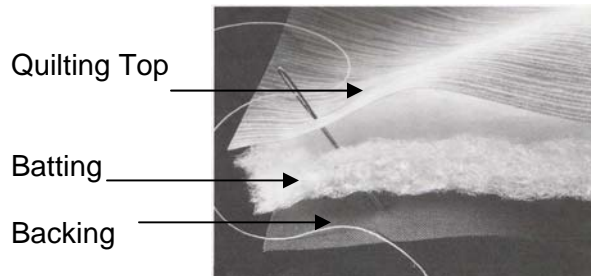

Before layering and hand-basting quilt, make sure all layers are smooth, seams pressed, and loose threads clipped from quilt top.

Cut backing fabric 2 to 4 inches larger than the quilt top on all four sides. A large project may require one or two seams on the quilt back as shown next.

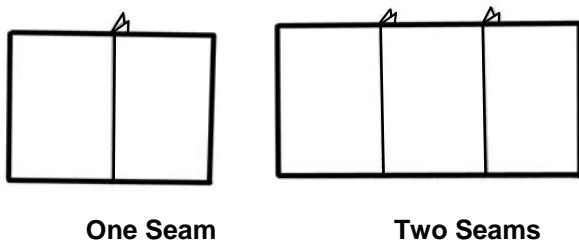

Lay backing on work surface, such as table(s) or floor, with wrong side facing up. Smooth the surface and square all corners. Masking tape can be used on corners and sides to hold in place while basting. Center batting on backing wrong side. Smooth the batting in place being careful not to stretch. Finally, center the quilt top face up, on the batting.

### Option 1: Hand Baste

For hand basting, use white, all-purpose thread with a long needle or curved basting needle. Put several yards of thread on your needle.

Basting stitches should be at 4- to 6-inch intervals.

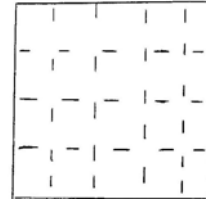

### Option 2: Pin Baste

Pin-baste the three layers together with safety pins. This method is preferred for machine quilting. Space pins at 4-inch intervals to avoid fabric shifting. Remove safety pins from quilting areas as you stitch.

### Option 3: Basting Sprays

Spray adhesives are available that work great for basting layers together. For light applications, spray adhesive above fabric surface and allow the spray to fall down onto the surface. Position next layer and repeat.

### Option 4: Basting Gun

This requires the purchase of plastic "tacks" that go in the gun. Quilt layers are tacked together at 4- to 6- inch intervals.

## HAND QUILTING

The **quilting hoop** is a piece of equipment used to hold a small portion of the quilt smooth and taut while the design is being sewn in place. It offers a more portable and compact way of quilting in place of the floor quilting frame.

Quilt hoops are usually constructed of wood and are available in various sizes and shapes. Quilt hoops are larger than embroidery hoops and are constructed with wider bands to accommodate the extra bulk of the three quilt layers. The quilt hoop consists of two parts:

1. Inner hoop
2. Outer hoop

The project should be hand basted before placing it in the quilt hoop. (See basting information in this handout.)

Begin quilting in the center of your project and work out to the edges.

Center the inner hoop under area to be quilted. Place outer hoop over basted quilt, slipping it down into place, and tighten. Quilting surface should be smooth. Turn hoop over and smooth out any wrinkles in the backing. Retighten after final adjustments.

Reposition hoop, as needed, to expose new areas to be quilted. To remove hoop, simply disassemble.

Do not leave the quilt “hooped” for long periods of time. Remove hoop after each quilting session to avoid unnecessary ring impressions in your fabric.

It is necessary to use a **thimble** while hand quilting. A thimble is a metal protective cap/guard used in sewing to protect the finger when pushing the needle. A quilting thimble has a raised edged with dimples on both the top and the sides that are deeply recessed to keep needle from slipping off. There are many different kinds of thimbles on the market. However, the quilting or “tailor’s thimble” is recommended for beginners. More experienced quilters may wish to explore other thimble possibilities.

Quilting needles are called **betweens**. Use a size 8, 10, or 12 between for hand quilting.

Betweens are short hand sewing needles. A higher number indicates a smaller needle. Different kinds of fabric will determine which size is best.

## THE HAND QUILTING STITCH

### Threading the Quilting Needle

Pull about 18-inches of quilting thread from the spool and thread the needle. Then cut the 18-inch length of thread from the spool. This ensures that the thread is used as it comes from the spool. If the needle is

threaded with the opposite end of the thread, it will tangle more often.

### Knoting the Thread

Tie a small knot at the end of the thread. Place the end of the thread along the needle with its end pointing toward the hand. Pinch this end of the thread and the needle with the needle hand. With the other hand, wrap the thread around the needle twice. Squeeze the wrapped thread tightly with the pointing finger and thumb of the needle hand. Pull the wrapped thread to the end of the thread to complete the knot. There will be a little tail of thread below the knot that will need to be clipped off.

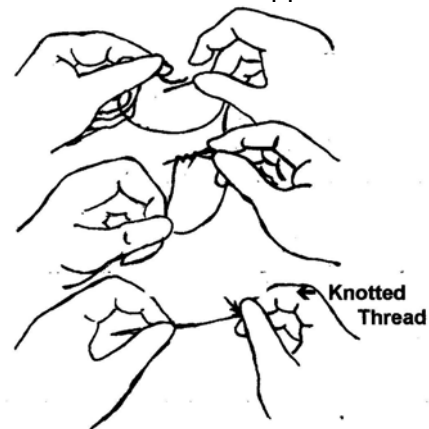

Choose a spot on the quilt about 1 inch from the spot where quilting will begin. Stick the needle through the top layer of the quilt sandwich and into the batting. Without going through the bottom layer of the quilt sandwich, run the needle through the batting to the spot where quilting will start.

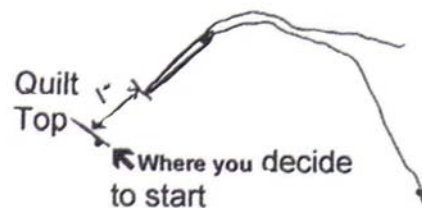

Pull the thread through and give the knot a little tug. This will “pop” the knot into the batting.

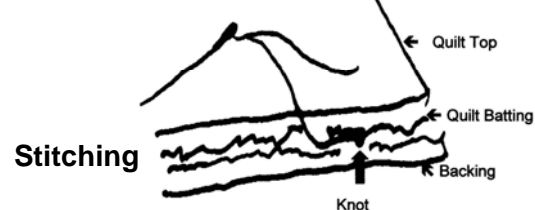

Touch the point of the needle to the quilt top in the place where quilting will start. Hold the needle straight up and down with the thimble that has been placed on the middle finger of the hand that you use most (right or left). Put the other hand under the quilt and place the middle finger of this hand where the needle point is. The point of the needle should be barely felt with this finger. Put the thumb of the top hand about ½ inch in front of the needle. Press down hard on the quilt top with the thumb. At the same time, push the needle through the mound that has been created with the thumb on the top and the middle finger on the bottom.

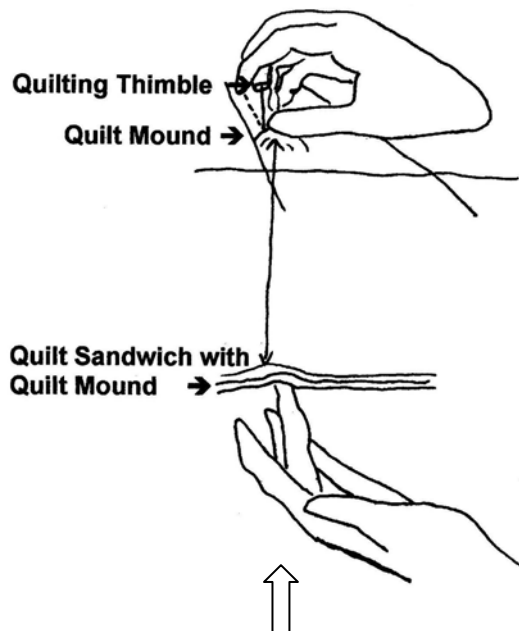

**When hand quilting, position the bottom hand so the middle finger will feel the tip of the needle as well as push up the quilt mound.**

As soon as the point of the needle comes out of the top of the mound, stop pushing and rock the needle to a straight up and down position again. There should be one little stitch on the needle. Gently push the needle through the sandwich until it is barely felt with the under middle finger, and begin the steps again for the second stitch.

This should be practiced until it is possible to get at least three stitches on the needle at a time. After there are three or four stitches on the needle, pull the needle all of the way through and pull the thread gently until the stitches lay flat. Be sure to pinch the thread at the needle eye while pulling or

the needle might come unthreaded. Begin another set of quilting stitches. This is referred to as the **rocking** stitch.

Place the needle point where the next stitch will begin. This should be the distance of one quilt stitch from where the thread comes out of the top from the last run of quilting stitches.

Try to keep the length of the quilting stitches even. In the beginning it is not as important to have tiny stitches, as it is to have each stitch exactly the length of the others. A good number of stitches to aim for are six stitches per inch. It will take a lot of practice to do this. Some really great quilters can get as many as 10 to 12 stitches per inch.

### Traveling

Traveling is a way of getting from one quilting section to another. This technique is recommended for going between areas that are 2 inches or closer together. Be sure to have plenty of thread remaining in the needle. Run needle through the batting only until it reaches the next starting point. If the area is more than the length of the needle, bring needle up through the quilt surface leaving the eye in the fabric. While holding the needle, pivot eye end in the direction of the next point. With thimble against the point of the needle, push needle back into batting, eye first towards new quilting line. If you have reached the new quilting line, bring needle through surface fabric and continue with the quilting stitch. Otherwise, pivot needle again and continue until you reach the new quilting line.

### Ending the Thread

When there is about 5 or 6 inches of thread left on the needle, it is time to tie off the thread and start with a new 18-inch length of thread. Make a circle with the thread on top of the quilt.

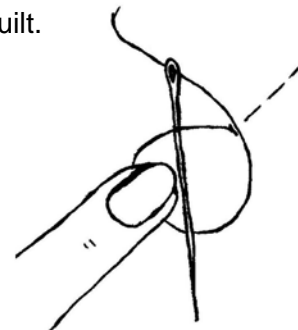

Bring the needle up through that circle. Hold the circle down with your finger while pulling the threaded needle to make the circle smaller and smaller. Try to get the knot to form about ¼ inch from the quilt top. Insert the quilting needle back into the same hole from which the thread is coming out of the quilt top. Do not make the needle come out the back but run it through the batting and out on top again about an inch or so away, and tug on the thread gently until the knot pops through the quilt top. Cut the thread close to the top and the thread end will disappear into the batting.

Another way to end a thread is to weave the needle back and forth through the stitches that have already been stitched. Do this by pushing the point and eye of the needle back and forth through the quilting stitches, never completely removing the needle from the quilt top.

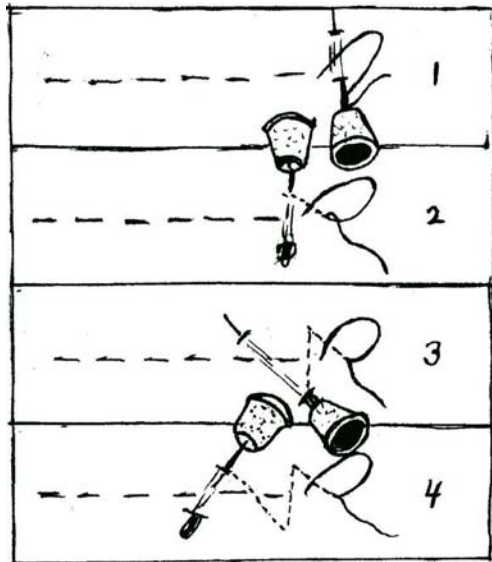

## MACHINE QUILTING

Machine quilting is much faster than hand quilting and can be very enjoyable.

### Work Area

It is important to have a good chair, preferably one that supports the back well. The sewing machine needs to be at a comfortable height and on or adjacent to a large-sized table with plenty of room to

support the quilting project, especially if the project is large.

### Preparations

The machine quilt project needs to be basted more closely than with hand quilting. (Refer to *Basting* section of this handout). The quilt will be manipulated and handled more while being machine quilted than with hand quilting. Fabrics are more likely to shift and wrinkle if it is not basted closely.

Choose a sewing machine needle that is appropriate for the fabric in the quilt. For cotton fabric and mid-loft batting, a # 12/80 is suggested. Use cotton thread that will match the quilt. If the quilt has many different colors, as most do, choose a color that coordinates/matches one of the colors. It is good to choose a thread color that will “disappear” or blend into the backing fabric. White is almost always acceptable. Clear, transparent nylon thread is also an option for machine quilting. For accent quilting, choose a contrasting or decorative thread.

If the sewing machine has the optional “needle down” feature, be sure to use it. If it does not, always try to end the stitching with the needle in the down position. This ensures straight quilting lines.

Practice sewing on scraps of the quilt sandwiches before starting to quilt the actual project itself.

Start the machine quilting in the center of the quilt and work out towards the edge. If the quilt is very large, it will be necessary to roll up both sides and slip one rolled side under the arm of the machine.

Position quilt under the presser foot and bring the bobbin thread to the surface of the machine. To do this, hold the top/needle thread and lower the needle into the machine. Bring the needle up again and gently tug on the thread to bring bobbin/lower thread loop to the surface. Pull the bobbin thread all the way out to the top.

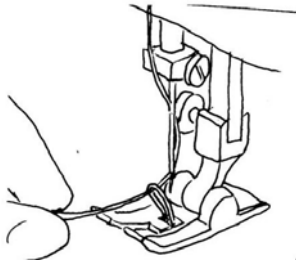

Hold both threads with your left hand as you begin to stitch just for a couple of small stitches to prevent loose thread ends from tangling underneath your stitching.

## KINDS OF MACHINE QUILTING

There are two kinds of machine quilting.

- ◆ Machine guided
- ◆ Free motion (Free Form)

### Machine Guided Quilting

Set the machine for a straight stitch with an average stitch length of 2.0 to 2.5mm (12 stitches per inch). Sometimes it is necessary to reduce the pressure on the presser foot because of the thickness of the three layers of the quilt. Some sewing machines will do this automatically; others have to be adjusted. Read and follow your sewing machine manual.

If possible, use a machine walking foot for quilting to assist in guiding and moving the fabric through the machine. This foot moves the top layer of the quilt through the machine at the same rate that the feed dog (teeth) moves the lower layer through the machine. This prevents tucks from happening at the intersections of the quilting.

If a walking foot is not available, there is a trick that can be used. Place your hands in front of the presser foot with fingertips together and elbows out. Fingers should be about 2 inches in front of the foot. Slide your fingertips across the top layer of the quilt, toward the presser foot, until there is a small bubble between fingertips and the

presser foot. *Use a light touch.* Don't move the batting or the back, just the quilt top.

As you sew, coax the bubble under the foot, but do not create a tuck! Use fingertips constantly to help the top layer of fabric feed smoothly under the foot. It is a small movement that will become automatic with practice. Doing this nudging action correctly, will prevent pleats on the quilt top when crossing lines of quilt stitching.

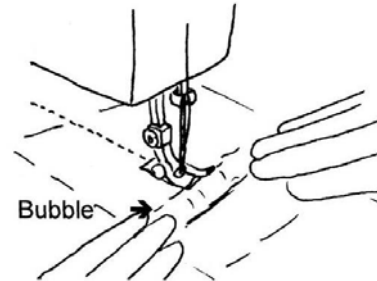

In preparation for stitching, be sure both the spool and bobbin threads are loose (not tangled) and to the back and left of the needle.

- ◆ Lower the presser foot where you want to start quilting.
- ◆ Begin and end each row of stitches with a "knot" to keep the stitching from coming loose. The best way to do this is to shorten the stitch length to 1.5 to 2.0 mm (15-16 stitches per inch) and stitch 7 to 8 stitches. Remember to reset the stitch length after making the "knot" at the start.

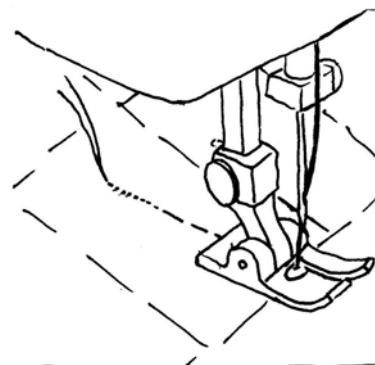

- ◆ Unroll and re-roll the quilt as stitching progresses. It is important to keep the quilt neatly controlled while stitching. Do not get in a hurry!
- ◆ When ending machine quilting, shorten the stitch length again for 7 to 8 stitches

to make an ending “knot” (*Remember to reset the stitch length each time after making a “knot”.*)

Try to keep the amount of quilting in each area of the piece the same. If one area is heavily quilted and another has very little quilting, the quilt will become wavy and crooked.

### Free Motion Quilting (free form)

When doing free-motion quilting, manually lower the sewing machine feed dog (the teeth) and attach a darning foot. Refer to your sewing machine manual. The darning foot is an attachment that usually comes with the machine. When the feed dog is lowered, the machine has no control over where the machine is stitching. *The sewer has all the control.* Free motion sewing is more like drawing than sewing. Practice is important to get the feel of the operation, and to manipulate the fabric consistently.

Before starting to stitch, it is important to lower the presser foot (this engages the tension control on your upper thread) and to use the needle down position on the machine, if this option is available on your machine. If not, manually lower the needle down into the fabric when stopping the machine.

To begin stitching, make sure bobbin thread has been pulled to the top side and both threads are loose and to the back and to the left of the needle.

- ◆ Lower the presser foot at the stitching point.
- ◆ Take very small stitches at the beginning for the first 7 to 8 stitches to lock/secure threads. Thread ends can be clipped next to the surface of the fabric later.
- ◆ Change stitch length back to regular machine stitch (approximately 12 stitches per inch) and resume stitching. Follow the predetermined quilting design. The sewer is in complete control of the stitch size. The fabric

moves as the sewer guides it. Place hands in a C-shape around the presser foot, and press down gently to move the quilt layers.



- ◆ Sew at a medium, even speed as the fabric is moved. The stitch length should be the same size as the machine guided stitches.
- ◆ “Knot” at the end of the stitching line the same as in the beginning.
- ◆ To move to a new spot, lift the presser foot and move the quilt to the next design. It is not necessary to cut the threads; it can be done later. Remember to lower the presser foot and needle and begin again with a new “knot.”
- ◆ It is important to keep the quilt in control. Unrolling and re-rolling as needed. Take your time and don’t hurry.
- ◆ Specially designed quilting gloves are available that will help your hands “grip” the fabric while quilting. Using these gloves may reduce stress on hands and shoulders.

## FINISHING TECHNIQUES

### Joining Prequilted Blocks

This technique is commonly referred to as “Quilt as You Go” or “Lap Quilting.” Each block is machine or hand quilted individually, then joined together to build an entire quilt. Quilters, who want a portable, take along project; suitable for vacation travel or lunch-hour quilting, prefer this method.



Place two prequilted blocks right sides together. Pin the batting and backing on each block away from the seam to be sewn. The fronts of the two blocks may now be pinned and machine or hand stitched with 1/4-inch seam allowance.

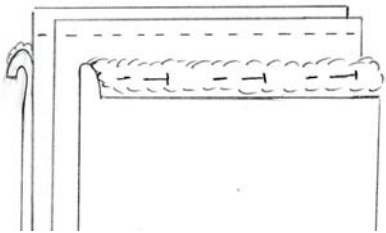

Open out the joined blocks face down. Finger-press the seam allowance to one side, and remove pins to release the batting only. Bring the batting together and trim so that the edges butt together with no overlapping. A large hand stitch (cross stitch or whipstitch) can be used to join butted edges of the batting together.

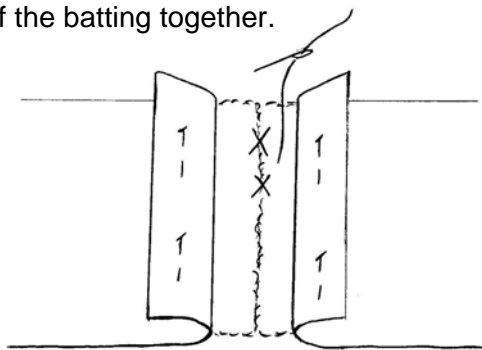

**Cross Stitch**

Remove pins from one side of the backing and smooth flat over the batting. Turn under 1/4-inch seam allowance along edge of the upper most backing piece. Pin and slip stitch folded edge to lower backing piece with matching thread.

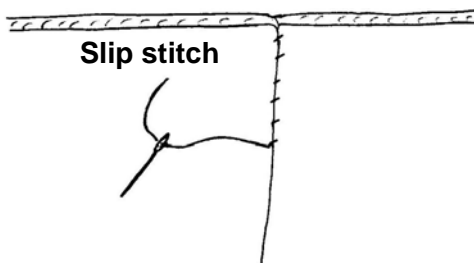

Continue to join blocks together to form rows. Once all rows are formed, they can be connected using this technique.

## Self-finished Edge

A turned-under hem may be used to finish the raw edge of the fabric. This creates a false binding. Trim batting even with quilt top. Trim backing fabric 1-inch wider than quilt top. Turn in the raw edge 1/2-inch and press. Bring folded edge over edge to cover batting and quilt top raw edge. Machine or hand stitch along the folded edge. Quilt top may also be cut wider than backing and folded to the back of the quilt.

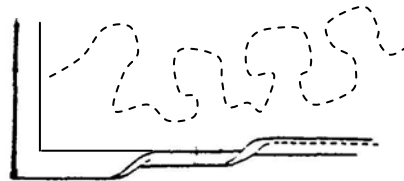

**Turned under and stitched**

## Fringing

Fringing is pulling out threads in a seam allowance to form a raveled edge.

Begin by machine stitching along the marked line of the project with a straight stitch. Stitch length should be reduced to a short stitch. To form fringe, unravel the fabric edges all the way up to the stitching line.

Some fabrics do not fringe easily. If this is the case, make cuts with scissors every two inches or so, just up to the stitching line. Take care not to cut into the stitching line. With a pin or needle, fringe small sections by pulling out horizontal threads.

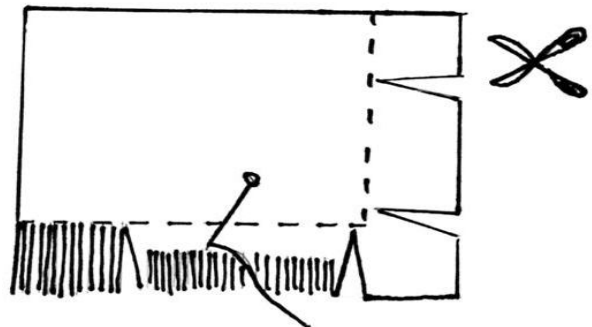

## BINDING

Binding encloses the fabric and batting of the outer edge of the quilt to create a finished edge. There are many types of

binding and various methods of application. Binding can be purchased or made from project fabric matching your quilt top.

Straight-grain binding (single or double folded) is suitable for any project unless you are binding curved or scalloped edges. Curves require bias binding, which stretches for a smooth, pucker-free finished edge.

Binding can be applied several ways, such as in one long continuous strip with mitered corners. Or each binding strip can be sewn in place separately producing overlapped finished corners. In addition, bias or straight-grain strips can be made in single or double thickness.

Before applying binding, hand or machine baste around project close to edge and within the ¼-inch seam allowance. If hanging sleeve is to be sewn into binding, see instructions at the end.

### Double Folded Binding

Following are instructions for double folded binding. Cut strips of binding 2¼ inches wide. (This width may be adjusted for wider binding and/or thicker quilts. Always do a test sample before cutting all the strips.) Cut enough strips to go around outside edges of quilt plus a few extra inches to allow for joining. Piecing can be avoided by cutting strips on the lengthwise of the fabric and makes for a firmer binding. When joining strips together, join on the diagonal to distribute bulk.

To join two strips, position strips perpendicular to each other, right sides facing, and stitch a diagonal joining seam.

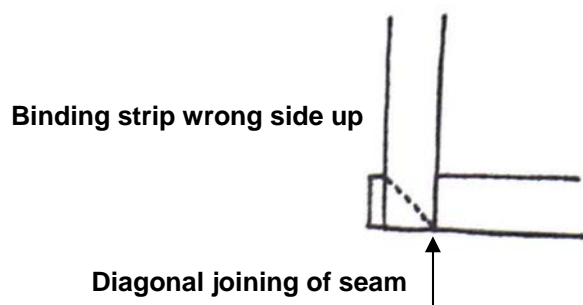

Trim ¼-inch seam allowance and press seam open.

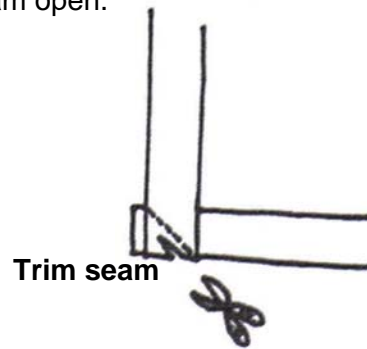

For directions on cutting continuous bias strips to be used for binding see: **CT-MMB.723 Continuous Bias Strips.**

Fold binding in half lengthwise and press.

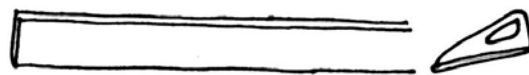

The folded edge provides a smooth, straight edge that can be easily stitched to the quilt back.

### Mitered Corner Application

1. Using an even-feed or walking foot will aid in sewing binding to the quilt top. Start stitching the unpressed edge of the binding to the right side of the quilt top at a point along one side. Do not start in a corner or the exact middle. Start your stitching about 4 inches from beginning end of binding. Stitch up to ¼ inch from the corner of the quilt. Pivot and stitch out to corner.

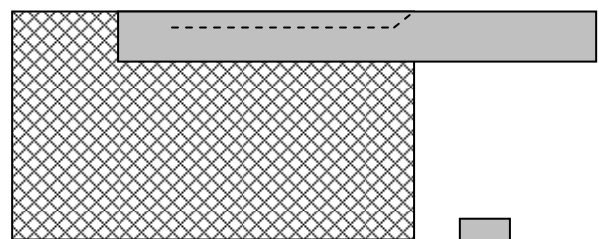

2. Lift presser foot and fold binding up along the diagonal stitching. This creates a miter.

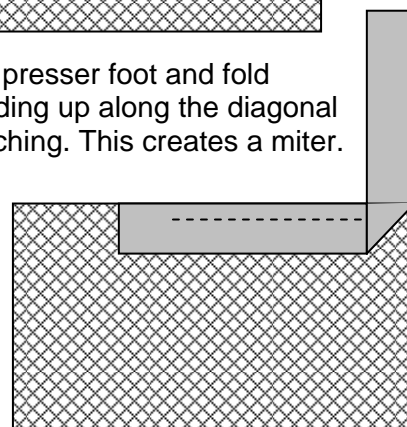

3. Fold binding straight down, lining up edges. Continue stitching to next corner as before and around remaining quilt sides.

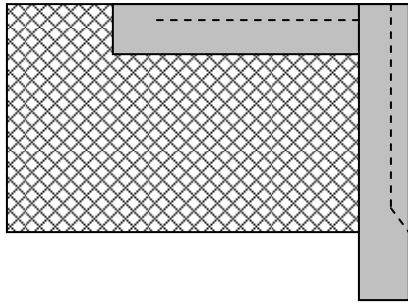

4. When you come around to the starting point, fold back binding and overlap or stitch the two binding ends together.
5. To stitch the ends together stop stitching approximately 8 inches from where beginning stitches started.

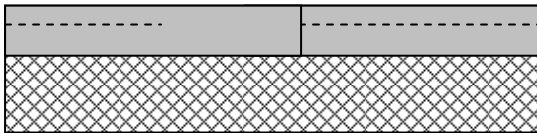

6. Open out binding and form 45° angle folds; crease folds.

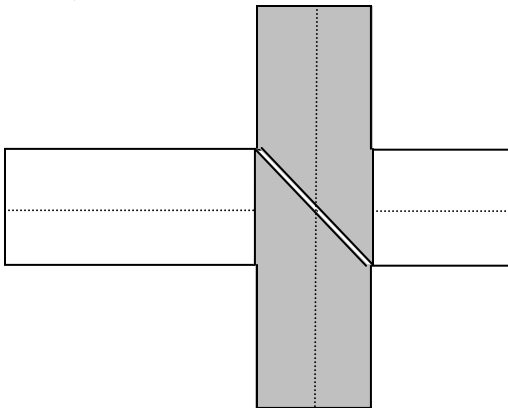

7. Open out diagonal folds. With right sides facing, match fold lines. Sew along diagonal creases. Trim seam allowance to ¼ inch and press open. Refold binding and stitch remaining area in place.

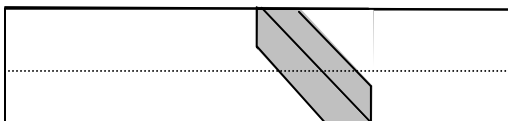

## Lapped Corner Application

Following are instructions for *straight-grain, double folded binding with lapped corners*. This method allows binding to be attached in four separate strips—one for each side of the quilt. The corners are trimmed, folded in, and sewn in place.

1. Hand or machine baste around project close to edge and within the ¼-inch seam allowance.
2. Determine amount of binding needed by measuring each side of project. Cut binding strips 2¼ inches wide selvage to selvage. Each strip should be cut approximately 4-inches longer than quilt length or width allowing for a 2-inch overhang at each corner. Opposite sides should have equal length binding strips.
3. Join strips diagonally as previously decided.
4. Fold binding strip in half to find midpoint. With raw edges of binding and quilt edges together, match midpoints of binding and quilt top. Pin in place with binding extending 2 inches beyond quilt edge. Using ¼-inch seam, machine stitch from corner to corner. Backstitch at each end. Repeat procedure, stitching binding to opposite side of quilt. Trim excess binding, backing, and batting even with quilt top.

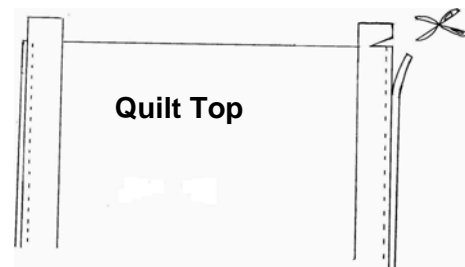

- Turn folded edge of binding over to quilt back, pin, and hand finish with a blind stitch covering previous line of machine stitches.

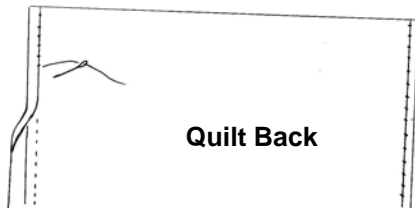

- Machine stitch binding strips to quilt top on remaining two sides leaving 2-inch over hang on each corner. Trim end of binding to 1/2-inch and fold trimmed edge in over previously applied binding.

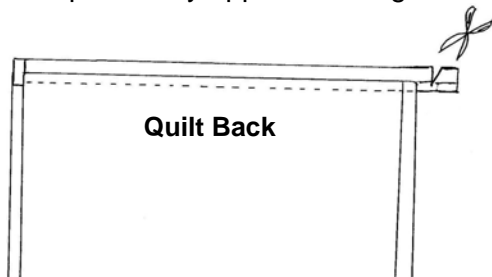

- Turn folded binding edge to quilt back; pin, and hand finish with blind stitch covering previous line of machine stitches. Extra stitches may be needed to secure corners.

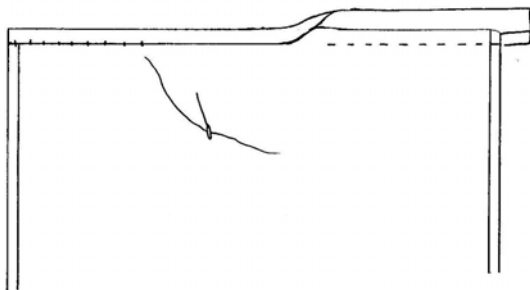

## HANGING SLEEVE

A hanging sleeve is a fabric tube attached to the quilt back, allowing it to be hung by an inserted rod. It should be applied after all quilting is complete. The sleeve can be added in conjunction with the binding application or hand sewn to a finished project.

If available, the hanging sleeve should be constructed of the same fabric as the backing.

### Option 1: Hand sewn to finished quilt

- To make a 4-inch sleeve, cut an 8 1/2 inch wide strip of fabric that is 2 inches shorter than the width of your quilt.

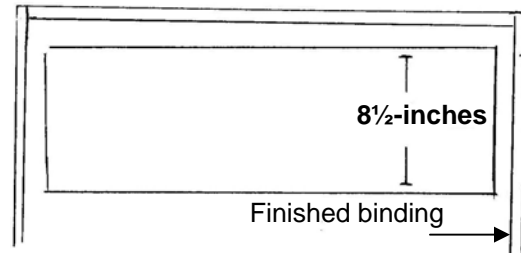

- Fold in half lengthwise, right sides together, and stitch a 1/4-inch seam allowance.

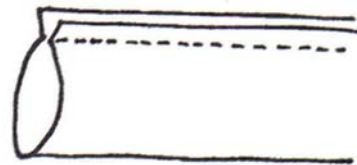

- Press seam allowance together and to one side. Hem sleeve ends by folding in raw edges and stitching. Turn sleeve to right side, and press the full length of sleeve to flatten, creating a top and bottom fold.

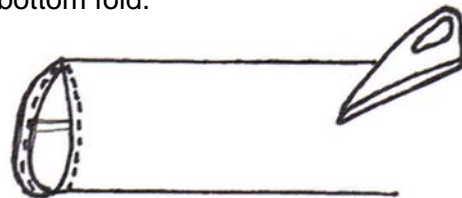

- Center and pin sleeve to quilt back just below edge of finished binding. Blind stitch in place along folded edges and ends of sleeve, taking care not to catch stitches in quilt top.

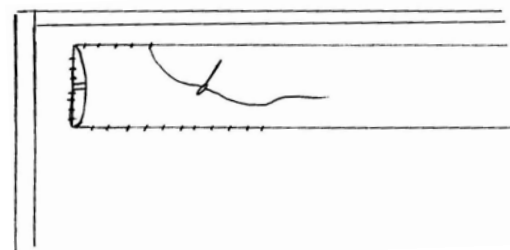

**Option 2: Sleeve added in conjunction with binding application**

1. To make a 4-inch sleeve, cut an 8 ½ inch wide strip of fabric that is 2 inches shorter than the width of your quilt.

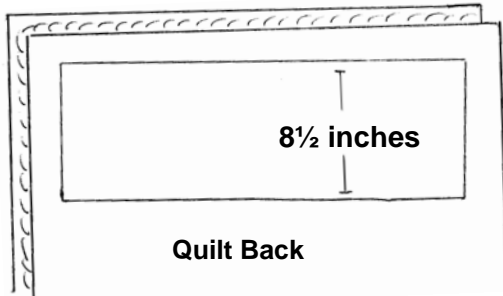

2. Hem sleeve ends with ¼ inch seam allowance. Fold in half lengthwise, with wrong sides together and raw edges meeting.

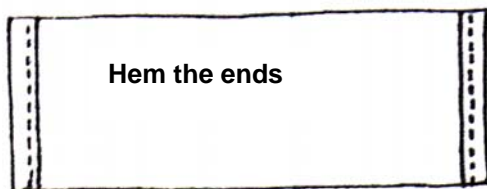

Press sleeve to flatten and crease bottom fold.

**Meet raw edges**

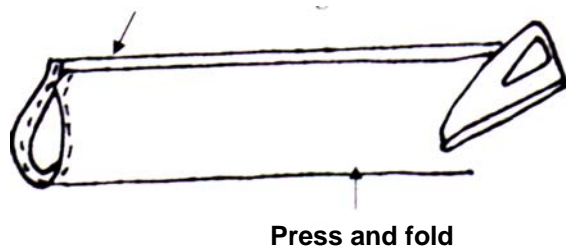

3. Center and pin sleeve to quilt back. Raw edges of sleeve should meet raw edges of quilt top. Machine-baste in place with scant ¼-inch seam allowance. Blind stitch bottom fold and ends of sleeve by hand. Take care not to catch stitches in quilt top.

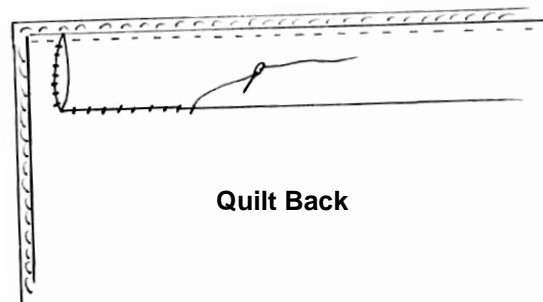

4. Proceed with binding application.

**References:**

Nita Benson, Kentucky Certified Master Clothing Volunteer  
 Karen Mikel, Kentucky Certified Master Clothing Volunteer  
 Judy Hetterman, County Extension Agent for Family and Consumer Sciences

Prepared by Marjorie M. Baker, M.S.  
 Extension Associate for Textiles and Clothing  
 April/2005